

THE AUSTRALIAN

NO 31 OCTOBER 2003

METROLOGIST

A publication of the Metrology Society of Australia

ISSN 1321-6082



**IMEKO
Featured**

**Legal Metrology
and Chemistry**

**Precision
Decimal
Measurement**

**Annual
General Meeting
Information**

From the Editor

This issue focuses on IMEKO, its activities and how the MSA interacts with it.

With the AGM of the society only weeks away, the notice and forms relating to it can be found on page 12 onwards.

The Crossword has closed, with no-one managing a correct entry. The solution is on page 23.

- Maurie Hooper

Correction

In TAM No 30 (July 2003), a number of significant errors occurred in the lead article "The Value of History" (pp. 2-3).

1. A shortcoming in the editing software resulted in the symbol Ω (for the unit of resistance, the ohm) being misrepresented as the letter W (the symbol for the unit of power, the watt) throughout the article.
2. The authorship of the article was attributed wrongly to Philip E Ciddor. In fact, the article contained material combined from a number of sources at NML (including Philip Ciddor), and was submitted as an NML news item.

The TAM editor apologises to Philip Ciddor for any adverse consequences of these mistakes.

Cover photo: Papyrus drawing to the Egyptian Book of the Dead. Weighing the soul of the Dead on the Day of Judgement, against a feather of the Goddess Ma'at. Anubis, the jackal-headed god of death carries out the weighing while Thoth, the ibis-headed god of wisdom writes down the verdict.

The Australian Metrologist

The Australian Metrologist is published four times per year by the Metrology Society of Australia Inc., an Association representing the interests of metrologists of all disciplines throughout Australia. Membership is available to all appropriately qualified and experienced individuals. Associate membership is also available.

Contributions

Articles, news, papers and letters, either via e-mail, disk or hard copy, should be sent to:

The Editor
The Australian Metrologist
11 Richland Road
NEWTON SA 5074
Phone: (08) 8365 2451
Fax: by arrangement only
E-mail: maurieh@ozemail.com.au

The deadline for the next issue is 16th December 2003.

Sponsorship/Advertising

Would you or your company be interested in sponsoring a future issue of *The Australian Metrologist*? If you are a Member or your company is in the metrology business, a contribution of \$400 permits the sponsor to include a relevant insert (up to A4 in size) in the mail-out. If you wish to place an advertisement in TAM, contact the Editor for current pricing.

Positions Wanted/Vacant

Need a Position?

Write or e-mail the Editor with your details including years of experience and qualifications. This service is offered free of charge.

Need a Metrologist?

If you have a position vacant, write or e-mail the Editor with the details. A charge of \$20 for up to 10 lines applies. (The circulation may be small but it is well targeted.)

The deadline for positions wanted/vacant is as above.

Letters to the Editor

Letters should normally be limited to about 200 words. Writers will be contacted if significant editorial changes are considered necessary.

Editorial Policy

The Editor welcomes all material relevant to the practice of Metrology. Non-original material submitted must identify the source and contact details of the author and publisher. The editor reserves the right to refuse material that may compromise the Metrology Society of Australia. Contributors may be contacted regarding verification of material.

Opinions expressed in *The Australian Metrologist* do not necessarily represent those of the Metrology Society of Australia. Material in this journal is © Metrology Society of Australia Inc. but may be reproduced with prior approval of the Editor.

Editor: Maurie Hooper

2003/4 Advertising Rates for The Australian Metrologist

| Space | One issue | Two issues | Three/Four issues | |
|-----------|-----------|------------|-------------------|--------|
| A4 page | \$400 | \$750 | \$1050 | 1/2 |
| Full page | \$225 | \$425 | \$600 | 1/3 |
| page | \$150 | \$130 | \$400 | 1/4 |
| page | \$115 | \$215 | \$290 | 1/8 |
| page | \$60 | \$110 | \$150 | Colour |
| Full page | \$800 | \$1,500 | \$2,100 | |

Insert one brochure in each TAM = \$300

Closing date for copy to be received for TAM is the 16th of the month preceding publication.

Contact the TAM editor for further details.

Please note: Camera ready artwork is to be supplied. Size and specifications are available from the editor. If extra typesetting etc is required an extra charge will apply. MSA members receive a 10% discount when they place advertisements in TAM.

MISA Membership Enquiries

Contact either your State Coordinators or the Secretary, Dr. Ilya Budovsky on (02) 9413 7201 or fax (02) 9413 7202, e-mail address Ilya.Budovsky@csiro.au or write to:

The Secretary, Metrology Society of Australia
c/o CSIRO National Measurement Laboratory
PO Box 218
LINDFIELD NSW 2070

The MSA website address is www.metrology.asn.au

Webmaster: Mark Thomas (03) 9244 4042 (wk)

MSA Membership Fees

| | |
|------------|--------------------------|
| Fellows | \$45 Joining Fee |
| | \$45 Annual Subscription |
| Members | \$40 Joining Fee |
| | \$40 Annual Subscription |
| Associates | \$35 Joining Fee |
| | \$35 Annual Subscription |

President's Report - October 2003

Good Measurement

What is good measurement practice? Is it being committed to maintaining your NATA accreditation, devoted to your ISO9000 system or is it something more? I was doing an audit recently and I started to wonder how often do we as metrologist's carry out good measurement that have no or little meaning. One of the essential underlying premises of accreditation systems and even uncertainty determination is that we understand what we are after. This may seem an obvious statement however often as scientist and technicians we get caught up in how we do our measurements not why or even what we are measuring!

What I am suggesting is that good metrology goes beyond calibration, traceability and uncertainty to a deeper understanding of what the knowledge is that is sought. I find it interesting that often when I as a customer have sought a calibration of an instrument from an external supplier, that more often than not I am not asked what the instrument is to be used for what the range of operation is or even where it will be used. Isn't it the responsibility of the metrologist to think outside the box and look at what the knowledge is that we seek? Do accreditation systems help or do they limit the view of the metrologist? I am quite intentionally taking an extreme view in the comments I have made. Personally I think that accreditation is essential to providing credible and reliable metrology but it is a tool not an end. We as metrologist have the responsibility to use the tool wisely and without hiding behind it as a safety blanket, "but I have accreditation, it must be right." We need to take responsibility and understand the limitation of the technologies we use and more importantly the limits of the world we wish to measure.

The latter is a significant problem because excepting for a few cases what we measure is normally an inference of what we want to know. A classic example of this is temperature measurement. Often what is actually sought after is the energy of a system but the temperature is taken as an approximation of this and uses a dimensional metrology based (thermometry) technology to provide us with the inferred value. The number of hidden assumptions in this example is enormous, but do we as metrologist take enough notice of them?

Understanding the limitations of the tools we use: technology, accreditation, uncertainty estimation, experimental design are important to being effective metrologist. One way of improving that understanding is to share our experiences at the biennial conference. MSA 2004 is being held in Melbourne in March 2004 and I hope that you will come, contribute to making it a great conference.

AGM

Yes the AGM is on it way again. This year it will be held at the new NML facilities and John Miles, now head of the Melbourne branch of NML, ex-President of the MSA and recently returned traveler from a secondment to the Institute for National Measurement Standards in Canada will be speaking at the AGM. There will be an opportunity to tour the facility and have a BBQ dinner with your fellow metrologists. If you are from interstate and intend to visit Melbourne around the time of the AGM please feel free to join us on the night. We are hoping that we will be able to organize teleconferencing facilities or possibly a video link for some of the interstate branches to join us. There will be further information about this closer to the date.

On a more serious note I am sorry to say that Marian Haire our Treasurer and Ilya Budovsky current Secretary and past vice-President will be leaving the National Committee this year after six years of great service to the society. I would like to extend my personal thanks to them both for the great job they have done and their support through the past few years. Their dedication and devotion to the Society has been pivotal in the society getting the stable footing it has now.

This however leaves a huge hole in the National Committee that will be hard to fill. I am therefore asking that you consider whether you would be prepared to step forward and join the National Committee and take the MSA into the future. Think about it and if someone taps you on the shoulder and asks if you'd consider joining the National Committee, then maybe say yes this time. It is a great way to contribute the metrological community and enjoy yourself along the way.

- Dr J Warne

Contents

| | |
|--|----|
| Advertising Rates | 2 |
| Editor's Notes | 2 |
| President's Report | 3 |
| IMEKO Feature - XVII World Congress | 4 |
| Information on IMEKO | 6 |
| Agreement with Croatian Metrology Society | 7 |
| IMEKO and your MSA | 9 |
| NML T&F Course | 11 |
| AGM notice and forms | 12 |
| IMEKO abstract | 15 |
| Legal metrology and Chemistry | 16 |
| Quantification | 17 |
| MSA Notes | 17 |
| Requirements for Precision Dimensional Measure- ment | 18 |
| MSA Members | 20 |
| Book Review | 23 |
| Crossword Solution | 23 |
| Management Committee | 23 |

Report on the XVII IMEKO World Congress

Ilya Budovsky

National Measurement Laboratory, CSIRO

In June 2003, as part of a business trip to Europe, I was fortunate to travel to Croatia to attend the XVII World Congress of the International Measurement Confederation (IMEKO). The congress was organised and run by the Croatian Metrology Society (HMD). The president of HMD, Prof Mladen Borši, was also the Chairman of the Congress.

There were more than 600 delegates. A total of 489 papers in 19 fields were presented. The welcome address by Prof Borši gives the following distribution of presenting authors: Australia (1), Austria (18), Belgium (6), Brazil (16), Canada (1), Chile (1), China (2), Croatia (24), Czech Republic (33), Egypt (2), Estonia (2), Finland (16), France (7), Germany (45), Greece (5), Hungary (9), India (1), Israel (3), Italy (60), Jamaica (1), Japan (35), Kenya (1), Lithuania (8), Macedonia (1), Malawi (2), Mexico (3), Morocco (1), Netherlands (8), Nigeria (1), Poland (61), Portugal (8), Republic of Korea (8), Romania (4), Russian Federation (16), Singapore (1), Slovakia (4), Slovenia (24), South Africa (1), Spain (6), Sweden (2), Switzerland (2), Taiwan (2), Turkey (7), Ukraine (4), United Kingdom (9), United States (10), Yugoslavia (1) and Zimbabwe (1). The cross-section of the measurement community represented by the delegates was equally wide, from students to the Director of the International Bureau of Weights and Measures, Dr Terry Quin, who delivered the opening lecture. It gave a fascinating incite on the history of the Metre Convention and its connection with past and present activities of the BIPM. Not surprisingly, most of the delegates came from universities, however some were from National Metrology Institutes (NMIs) and some from industry. Overall, seeing and being part of such a large forum of people professionally involved in measurements helps one gain confidence that metrology is, indeed, flourishing.

On the first day I presented a paper on the new facility developed at NML to provide traceability to low-frequency EMC testing equipment such as precision harmonics and flicker analysers. As expected, there were quite a few people in the

audience concerned with the developing area of low-frequency EMC measurements, so the paper was met with interest and discussions continued afterwards. On the same day I chaired one of the sessions in the electrical stream.

On Tuesday an unusual session by name of "New Challengers" took place. At this session, representatives of seven of the world's leading NMIs were asked to present invited papers introducing research and activities of their institutes in the present dynamic times. I delivered a paper on the National Measurement Laboratory and its role in the Australian Standards and Conformance system. This was a perfect opportunity to share the news of the recent decision by the Australian Government to combine, effective from 1 July 2004, NML, National Standards Commission (NSC) and Australian Government Analytical Laboratory (AGAL) in a new Australian NMI. The news was accepted with interest and enthusiasm. In comments from the floor people were congratulating us on uniting physical, chemical and legal metrology in one institution. The other papers of the session were presented by Dr Tanaka (NMIJ, Japan), Dr Ferrero (IMGC, Italy), Dr Schwitz (METAS, Switzerland), Dr Bennet (NPL, United Kingdom) and Dr Kochsiek (PTB, Germany). Following numerous requests, the presentations from the "New Challengers" session were put on a CD and distributed to the attendees.

Needless to say, Croatian Metrology Society <http://www.hmd.hr/english/index.htm> did a remarkable job organising an event with a budget in excess of half a million Australian dollars. Everything was perfect and on time and the atmosphere of cooperation and free exchange of ideas between people from different countries and areas of metrology was truly amazing. There was even a daily issued newsletter. The organisation of the Congress was almost entirely paperless. Everything was arranged through the Internet (see <http://www.hmd.hr/imeko/> where one can still find summaries of all papers). The digest containing full papers is available to MSA members on CD upon request.

From my discussions with Prof. Borši and Prof. Butorac, it became clear that MSA and HMD are strikingly similar in their goals and structure. It was in those discussions that the idea of an agreement of cooperation between MSA and HMD arose. This agreement was prepared and signed during a special ceremony that followed the "New Challenges". An account of this, including the photograph was, of course, published in the newsletter on the next day. The text of the agreement is enclosed.

On Wednesday, as a representative of the MSA, I took part in the meeting of the General Council of IMEKO, which brings me to the issue of IMEKO and the Australian participation in it. After familiarising oneself with IMEKO and its structure, an analogy that comes to mind is between IMEKO and MSA. In MSA most of the work is performed in the State Branches. In IMEKO most of the work takes place in its 20 Technical Committees. The Technical Committees (see information on IMEKO below) organise events (conferences, symposiums, workshops, etc.), publish proceedings of events, text-books, glossaries, studies, etc. and, just like MSA is as good as its State branches and the members who take part in the events, IMEKO is just as good as its Technical Committees.

In accordance with the rules of IMEKO, any country can be represented by one organisation only. MSA is the member organisation for Australia. Each member organisation can appoint a representative to every Technical Committee. In my opinion, MSA should immediately take advantage of this opportunity, which will give the members a wealth of information and possibilities (particularly as MSA is offering subsidies for attendance at events). MSA representatives in IMEKO Technical Committees should be the point of contact with IMEKO to all members and their list should be published in TAM and on the web. It seems that this alone would make MSA contributions to IMEKO (currently US\$450 per year) worthwhile. With this in mind, the MSA National Committee recently appointed Marian Haire as the liaison person with IMEKO and also appointed Marian to TC1 and myself to TC4. The National Committee is currently looking to fill in the other vacancies and expressions of interest would be most welcome, particularly from members who may be likely to travel for work. If you would like to contribute, please contact Marian on MHaire@nsc.gov.au.

Finally, a few words about the venue and other perks. The Congress was held in Cavtat, a quiet and extremely picturesque seaside town approxi-



Agreement of Cooperation between MSA and HMD was signed by Dr Ilya Budovsky, Secretary of MSA and Dr Mladen Borši, President of HMD. Photograph taken from the XVII IMEKO Congress Newsletter.

mately 20 minutes away from Dubrovnik. The venue, Hotel Croatia, is an impressive five star establishment built in the "old" times of the former socialist Yugoslavia. The new owners seem to have done a great job in preserving the communist legacy, including impressive and well equipped lecture rooms, private beaches, tennis courts and other "essentials". Not surprisingly, the cost of rooms was not the lowest I have seen, so, like many other delegates, I explored other alternatives such as private accommodation. I ended up living at the very top of a medieval street consisting entirely of a long and winding staircase between two stone walls. No cars.

However, the old city of Dubrovnik turned out to be by far the most impressive. A very small fortress built on a peninsula and surrounded by centuries-old walls (see cover of TAM No 27) is a true wonder of the world. Very carefully planned, its narrow streets of stone have been polished to shine by millions of feet. The cross-section of Dubrovnik is parabolic, the main and the only wide street being the lowest and buildings nesting on the hills on both sides of the main street. Remarkably, from the 12th century, the laws of the Republic of Dubrovnik did not allow anyone, albeit a very rich person, to build a house with a roof higher than the house above so that everyone could have a view. Something Australian councils are just catching up with! Dubrovnik has survived

many attacks, including the Serbian aggression of 1991 when the city was heavily bombed from the nearby hills. During that time, 95% of the original tiles were lost and consequently replaced by UNESCO. The replacement tiles were, I think, deliberately chosen to contrast the remaining ones. No damage to the 10-meter thick walls though. It seems they have been built with more than 95% degree of confidence!

The next IMEKO Congress will be held in 2006 in Rio De Janeiro (Brazil).

Agreement of Cooperation between The Metrology Society of Australia and The Croatian Metrology Society - see page 7.

Information on IMEKO

(from <http://www.imeko.org/>)

IMEKO is a non-governmental federation of 35 Member Organizations individually concerned with the advancement of measurement technology.

Its fundamental objectives are the promotion of international interchange of scientific and technical information in the field of measurement and instrumentation and the enhancement of international co-operation among scientists and engineers from research and industry.

Founded in 1958, the Confederation has consultative status with UNESCO and UNIDO and is one of the five Sister Federations within FIACC: Five International Associations Co-ordinating Committee, further consisting of

- IFAC - International Federation of Automatic Control,
- IFIP - International Federation for Information Processing,
- IFORS - International Federation of Operational Research Societies and
- IMACS - International Association for Mathematics and Computers in Simulation.

The seat of the IMEKO Secretariat is in Budapest, Hungary. Secretary: Ms. Karolina Havrilla.

The activity of IMEKO is basically carried out through the Technical Committees which

- organize symposia, conferences, workshops, seminars on specific topics at regular intervals;
- publish proceedings of events, text-books,

glossaries, studies, etc.

to realize the objectives set out in the Constitution and By-Laws.

TECHNICAL COMMITTEES of IMEKO

- TC1 - Education and Training in Measurement and Instrumentation
- TC2 - Photonics
- TC3 - Measurement of Force, Mass and Torque
- TC4 - Measurement of Electrical Quantities
- TC5 - Hardness Measurement
- TC6 - Vocabulary Committee
- TC7 - Measurement Science
- TC8 - Traceability in Metrology
- TC9 - Flow Measurement
- TC10 - Technical Diagnostics
- TC11 - Metrological Infrastructures
- TC12 - Temperature and Thermal Measurements
- TC13 - Measurements in Biology and Medicine
- TC14 - Measurement of Geometrical Quantities
- TC15 - Experimental Mechanics
- TC16 - Pressure and Vacuum Measurement
- TC17 - Measurement in Robotics
- TC18 - Measurement of Human Functions
- TC19 - Environmental Measurement
- TC20 - Measurement Techniques for the Construction Industry

TC1 - Education and Training in Measurement and Instrumentation (established in: 1967)

Chairman: Prof. dr. ir. P. P. L. Regtien
University of Twente
Faculty of Electric Engineering
Laboratory for Measurement and Instrumentation
P.O. Box 217 7500 AE Enschede
The NETHERLANDS
Phone: +31 53 489 2782
Fax: +31 53 489 1067
E-mail: p.p.l.regtien@el.utwente.nl

TC2 - Photonics (established in: 1962)

Chairman: Prof. Dr.-Ing. T. Pfeifer
RWTH Aachen
Lehrstuhl für Fertigungsmesstechnik und Qualitätsmanagement
Werkzeugmaschinenlabor
Steinbachstrasse 53 52074 Aachen
GERMANY
Phone: +49 241 807 412
Fax: +49 241 8888 193
E-mail: t.pfeifer@wzl.rwth-aachen.de

TC3 - Measurement of Force, Mass and Torque (established in: 1967)

Chairman: Dr. D. I. Kang
Korea Research Institute of Standards and Science



**Metrology Society
of Australia**

**Agreement of Cooperation between
The Metrology Society of Australia and
The Croatian Metrology Society**

This memo outlines the basis of the cooperation established under this Agreement of Cooperation between the Croatian Metrology Society (HMD) and the Metrology Society of Australia (MSA).

The undersigned organisations understand and strongly believe that it would be of great benefit to both organisations to have a more active membership. Giving to all members an opportunity to be kept more informed of events in international metrology and related activities through this Agreement of Cooperation aid this objective.

Both organisations shall act to share information by having members of similar subcommittees of their respective organisations set up regular lines of communication. Each shall include the partner organisation on its mailing lists for members' bulletins. In its regular publications each organisation shall offer and provide space for publishing current activities of the partner organisation.

Both organisations shall seek to identify potential areas of cooperation, including the following:

- Exploring the possibility of presenting papers at each other's conferences and promoting these conferences in all available newsletters.
- Making joint submissions to such international bodies as IMEKO.
- Identifying issues of national importance in which metrology is a critical factor and promoting joint activity between their national economies at a governmental level on such issues.
- Facilitating visits by each Society's members to the partner's country for technical interaction.

Unless otherwise stated, each partner shall cover its own costs of participation in any cooperative activity.

This Agreement of Cooperation is the appropriate instrument under which joint projects, studies and other cooperation can be established, with the understanding that each action shall be individually stated and approved by both partners before its execution. Until further notice, as a formal means of communication, undersigned members will serve as Liaison Delegates to interact on behalf of their organisations with partner organisation.

Agreed this June 25th, 2003

for the Metrology Society of Australia

Ilya Budovsky, MSA Secretary

for the Croatian of Metrology Society

Mladen Boršić, HMD President

P.O.Box 102 Yusong, Taejon, 305-600
REPUBLIC OF KOREA
Phone: +82-42-868-5010
Fax: +82-42-868-5012
E-mail: dikang@kriss.re.kr

TC4 - Measurement of Electrical Quantities

(established in: 1984)

Chairman: Dr. M. Sedláček
Czech Technical University
Faculty of Electrical Eng., Dept. of Measurement
Technická 2
16627 Praha 6

CZECH REPUBLIC
Phone: +420 2 2435 2177
Fax: +420 2 3333 9929
E-mail: sedlacem@feld.cvut.cz

TC5 - Hardness Measurement (established in:
1973)

Chairman: Dr. K. Herrmann
Physikalisch-Technische Bundesanstalt
5.102 Härtemessung
Bundesallee 100, 38116 Braunschweig
GERMANY
Phone: +49 531 592 5140

Fax: +49 531 592 695140
E-mail: konrad.herrmann@ptb.de

TC6 - Vocabulary Committee (established in:
1974)
activity suspended

TC7 - Measurement Science (established in:
1975)
Chairman: Prof. Dr. R. Z. Morawski
Faculty of Electronics and Information Technology
Warsaw University of Technology
ul. Nowowiejska 15/19, 00-665 Warsaw
POLAND
Phone: +48 22 825 3758
Fax: +48 22 825 1984
E-mail: r.morawski@ire.pw.edu.pl

TC8 - Traceability in Metrology (established in:
1972)
Chairman: Dr. S. D'Emilio
Istituto Elettrotecnico Nazionale "G. Ferraris"
Strada delle Cacce, 91
10125 Torino ITALY
Phone: +39 011 39 19 546
Fax: +39 011 34 63 84
E-mail: demilio@me.ien.it

TC9 - Flow Measurement (established in: 1976)
Chairman: Dr. M. J. Reader-Harris
National Engineering Laboratory
East Kilbride, Glasgow G75 0QU
UNITED KINGDOM
Phone: +44 1355 272 302
Fax: +44 1355 272 536
E-mail: mreader@nel.uk

TC10 - Technical Diagnostics (established in:
1976)
Chairman: Prof. Dr.-Ing. D. Barschdorff
Elektrische Messtechnik
Universität - GH
Fachbereich 14
Warburger Str. 100, 33098 Paderborn
GERMANY
Phone: +49 5251 603 022
Fax: +49 5251 603 237
E-mail: diebar@emt.uni-paderborn.de

TC11 - Metrological Infrastructures (established
in: 1976)
Chairman: Dr. E. Seiler
Physikalisch-Technische Bundesanstalt
Q.5 Technische Zusammenarbeit
Bundesallee 100
38116 Braunschweig GERMANY

Phone: +49 531 592 8200
Fax: +49 531 592 8225
E-mail: eberhard.seiler@ptb.de

TC12 - Temperature and Thermal Measurements
(established in: 1979)
Chairman: Dr. F. Righini
CNR Istituto di Metrologia "G. Colonnetti"
Strada delle Cacce, 73
10135 Torino, ITALY
Phone: +39 011 397 7342
Fax: +39 011 397 7347
E-mail: f.righini@imgc.cnr.it

TC13 - Measurements in Biology and Medicine
(established in: 1980)
Chairman: to be elected

TC14 - Measurement of Geometrical Quantities
(established in: 1980)
Chairman: Prof. Dr.-Ing. A. Weckenmann
Qualitätsmanagement und Fertigungsmesstechnik
Universität Erlangen-Nürnberg
Nägelsbachstr. 25
91052 Erlangen GERMANY
Phone: +49 913 1852 6520
Fax: +49 913 1852 6524
E-mail: weckenmann@qfm.uni-erlangen.de

TC15 - Experimental Mechanics (established in:
1984)
Chairman: Prof. A. Freddi
Università di Bologna DIEM - Dip. di
Meccanica e Aeronautica
Viale Risorgimento, 2
40136 Bologna ITALY
Phone: +39 051 209 3455
Fax: +39 051 209 3412
E-mail: alessandro.freddi@mail.ing.unibo.it

TC16 - Pressure and Vacuum Measurement
(established in: 1986)
Chairman: Dr. A. Ooiwa
National Metrology Institute of Japan
National Institute of Advanced Industrial Science
and Technology
Central 3, 1-1, Umezono
1-chome, Tsukuba 305-8563 JAPAN
Phone: +81 298 61 4024
Fax: +81 298 61 4020
E-mail: ooiwa@nrlm.go.jp

TC17 - Measurement in Robotics (established in:
1987)
Chairman: Prof. S. Tachi
Dept. of Mathematical Engineering and Information
Physics

The University of Tokyo
7-3-1- Hongo, Bunkyo-ku
Tokyo 113 - 8656 JAPAN
Phone: +81 3 5841 6915
Fax: +81 3 5841 8595
E-mail: tachi@star.t.u-tokyo.ac.jp

TC18 - Measurement of Human Functions (established in: 1998)

Chairman: Prof. K. Ito
Department of Computational Intelligence and Systems Science
Interdisciplinary Graduate School of Science and Engineering
Tokyo Institute of Technology
4259, Nagatsuta, Midori-ku
Yokohama 226 JAPAN
Phone: +81 45 924 5655
Fax: +81 45 924 5684
E-mail: ito@dis.titech.ac.jp

TC19 - Environmental Measurement (established in: 1999)

Chairman: Dr. S. E. Smith
Department of Civil Engineering
University of Florida
Gainesville, FL 32611 USA
Phone: +1 352 392 4990
Fax: +1 352 392 4957
E-mail: ses@ce.ufl.edu

TC20 - Measurement Techniques for the Construction Industry (established in: 1999)

Chairman: Dr. K. Hariri
Technical University Braunschweig
Institut für Baustoffe, Massivbau und Brandschutz
Beethovenstr. 52
38106 Braunschweig GERMANY
Phone: +49 531 391 5487
Fax: +49 531 391 8289
E-mail: k.hariri@tu-bs.de

IMEKO and your MSA ... If it's to be its up to you!

Marian Haire

For some years now MSA has been the Australian representative on IMEKO. Many times I have heard members of the MSA national committee say: "What is IMEKO exactly?" No doubt many of you feel the same. The easy answer to this question is IMEKO is an international group of metrologists who are interested in sharing information related to metrology. IMEKO is the International Measurement Confederation founded in 1958, primarily as a mechanism to bridge the gap between scientists in Western and Eastern Europe. IMEKO's fundamental objectives are the promotion of international interchange of scientific and technical information in the field of measurement and instrumentation, and the enhancement of international co-operation among scientists and engineers from research and industry. It is a non-governmental federation of 35 Member Organisations (MO's) individually concerned with the advancement of measurement technology and each representing a particular national economy. The member economies are: Albania, Australia, Austria, Belgium, Brazil, China, Croatia, Czech Republic, Egypt, Finland, France, Germany, Greece, Hungary, Israel, Italy, Japan, Kenya, Korea (republic of), Mexico, New Zealand, Poland, Portugal, Romania, Russia, Slovakia, Slovenia, South Africa, Spain, Sweden, Switzerland, The Netherlands, Turkey, United Kingdom, and the United States of America.

The work of IMEKO is very much aligned with the goals of MSA. It is our way of reaching out to like-minded people in other parts of the world. IMEKO holds a world congress regularly, at a different venue each time. These cover the full gamut of measurement activities and generally attract the participation of over 1000 delegates. They are advertised well in advance. MSA is willing to provide support for members to attend as MSA representatives. See the website for venues. You may be able to align other work commitments so you are able to attend.

IMEKO publishes the proceedings of its conferences and a quarterly scientific journal, *Measurement*, through Elsevier Science Ltd, Oxford, UK. All MO's receive a subscription to this journal. Visit <http://www.elsevier.nl/locate/measurement> to view past issues and perhaps find an article that you will find useful in your work. You will at least gain an appreciation of the wealth of knowledge that is available to MSA through the membership of IMEKO.

Dr Ilya Budovsky attended the recent XVII IMEKO World Congress in Croatia and has provided a report and a list of IMEKO committees. These committees vary widely in depth of membership and level of activity. However, they offer the MO's access to a global network of expertise and influence that can be very useful to individual

committee members, to the overall MO's membership, and to the MO's nation as a whole. They commonly hold specialist meetings and workshops. Further information about IMEKO can be obtained at: <http://www.imeko.org/>

A Proposed Strategy for Maximisation of Benefits

In 2001 Dr Laurie Besley prepared a proposal outlining how MSA could get value from its relationship with IMEKO. The national committee has agreed that the MSA should endeavour to evaluate IMEKO membership after attempting to carry out this plan. At the moment we feel that we are footing the bill for Australia's involvement without gaining many direct benefits.

The proposition is that for a trial period of three years from January 2001, the MSA should endeavour to maximise its interaction with IMEKO and then evaluate the results. To do this we should allocate a sum of \$4,500 a year to support our involvement. This is a significant sum, the annual commitment representing 25% of the Society's annual income from subscriptions and the 3-year expenditure amounting to about 22% of our accumulated assets.

Of this \$4500 p.a., about \$1800 would be expended immediately on our IMEKO membership fee. We currently pay US \$450 membership, half the rate a member economy of our size should pay. The remainder would be used to support the involvement of our representatives in meetings of the IMEKO conferences and meetings of the IMEKO technical committees. We would try to place as many representatives as possible on these technical committees to feed information back to the membership. At the end of the 3-year period, the effectiveness of this expenditure and of the MSA's role as Australia's IMEKO member organisation would be reviewed and a decision made on whether our involvement should continue.

An additional proposition is that the MSA should seek Australian Government funding to act as Australia's representative on IMEKO. If this were achieved it would remove the financial burden on the Society but might mean that the information gleaned from IMEKO would need to be made available to all Australians regardless of their MSA membership. To date we have not identified any avenue that would make such government funding available to MSA.

The following action plan was developed – italics described outcome to date:

- Form an MSA subcommittee to manage interactions with IMEKO. *Not achieved*
- Approach IMEKO for a reduced membership fee rate of US\$450 p.a., the approach based on the small membership and limited financial resources of the MSA. *Achieved for a limited period*
- Seek IMEKO sponsorship of the MSA'01 and subsequent MSA conferences. *Not achieved*
- Request IMEKO to fund a representative to attend MSA conferences. *Not achieved for MSA '01*
- Approach IMEKO for permission to publish in TAM one article per issue from the IMEKO journal *Measurement*. *Currently seeking this permission*
- Appoint one MSA member to each of the technical committees of IMEKO 2/20 *achieved*
- Require each of these technical committee members to present a report on the committee's activities annually in TAM. *Not achieved*
- Solicit papers from MSA members to be submitted to *Measurement* for publication. *Not achieved*
- Seek Australian government sponsorship of the MSA's IMEKO membership (\$ for \$ for our contribution, perhaps, or money (say, \$6,000 p.a.) to send a representative to every IMEKO general council meeting and congress). *Not achieved*
- Allocate three grants annually of \$ 900 each to assist the attendance of two technical committee members at the meeting/workshop of their corresponding technical committee. Award of the grants to be based on a series of criteria, including the importance of the area to the MSA's members and the intensity of the member's interaction with the committee. *One grant provided to date.*
- Identify activities for IMEKO that would assist the MSA's members and use our IMEKO membership to lobby for those activities. *Not achieved*
- After some or all of these components were put into place over three years, evaluate the success of this concentrated effort in the first months of 2004.
- If it were decided to continue the MSA involvement, promote Sydney or Melbourne as the host city for the 2008 or 2010 IMEKO World Congress. Approach the Australian government

and/or the relevant state government for financial support and involvement. Use IMEKO as a vehicle to publicise the importance of metrology to an industrial economy.

Like any other member driven organisation its worth is related to the amount of interaction you are willing to engage in. As my term as Treasurer is coming to an end and I would like to maintain an involvement with MSA, I have taken on the role of IMEKO Liaison Officer. My main aim in doing this is to locate 18 metrologists within Australia who are willing to participate on one IMEKO committee. Their role would be to share their own expertise with other committee members and also to share information within Australia through TAM. Currently we have 2 representatives on committees. Even if you agree to be a member of sub-committee it takes some time to become an active participating member. I have been nomi-

nated by the national committee but will not be appointed to the Technical Committee on Education committee until May 2004. However you have to start somewhere so please if you have an interest in assisting MSA by being a representative on a technical committee in your area of expertise let me know. Also please let me know if you believe we should continue to be involved as a member organisation of IMEKO and make suggestions for how we can make this work for the whole MSA membership.

This article includes the bulk of a report Dr Laurie Besley presented to the MSA national committee when he was secretary of MSA. I felt it was a useful place to start. It provides members with an overview of the plan and the progress made to date. Evaluation time is next year. If we don't achieve more I believe we will have to make a difficult decision. ■

Time & Frequency training course

CSIRO National Measurement Laboratory will be running a two day intensive course on Time and Frequency measurement and standards at its West Lindfield laboratory in Sydney on 17-18 November 2003. The course provides an opportunity to gain knowledge about general principles of measurement as well as specific techniques. It consists of lectures, demonstrations and laboratory tours. It will be of value to technicians, engineers, scientists and others involved in or responsible for work in laboratories in which the measurement of time and/or frequency is important.

To obtain a brochure on this course contact Mrs Jan Brett by:

Mail: CSIRO National Measurement Laboratory, Melbourne Branch
Locked Bag 700 CLAYTON SOUTH VIC 3169

Phone: 03 9545 8225

Fax: 03 9545 8260

Email: Jan.Brett@csiro.au

**Find out about NML's other training courses at
<http://www.nml.csiro.au/Services/training.htm>**

**ANNOUNCEMENT AND INVITATION TO THE
ANNUAL GENERAL MEETING FOR THE MSA 2003**
TO BE HELD AT THE
National Measurement Laboratory, Clayton.

WEDNESDAY 12TH NOVEMBER, 2003 AT 6:00 PM

FORMAL AGM FOLLOWED BY BBQ, TOUR OF THE NML AND TALK BY
DR JOHN MILES, LEADER NML MELBOURNE
AND FOUNDING PRESIDENT OF THE MSA.

The agenda for the meeting will be as follows

- Apologies
- Minutes of the previous AGM and subsequent special General Meeting
- President's and Treasurers Reports
- Recommendation of fees
- Election of Office bearers
- Discussion and vote on tabled motions
- Close of meeting

Nominations for the National Committee of Management are sought and should be with the Secretary Ilya Budovsky no later than close of business on the 5th November 2003.

This will be followed by a BBQ dinner where all food and soft drinks will be provided; beer and wine will be available at bar prices. For catering purposes could you please indicate your intention to attend the evenings festivities to Jane Warne by e-mail at J.Warne@bom.gov.au or phone (03) 9669 4721.

SPEAKER DR JOHN MILES

the newly appointed Officer-in-Charge of NML Melbourne has recently returned from an extended secondment to the Canadian Institute for National Measurement Standards

There will also be an opportunity to tour the new facilities of NML at Clayton.

Motions

1. That the fees for membership of the MSA remain at the current level of \$45 for a fellow, \$40 for a member and \$35 for an associate for a further twelve month period.
2. That Ron Cook be elected to the membership of Honorary Fellow of the MSA for his outstanding contribution to both the field of Metrology and the Metrology Society of Australia.
3. That Alex Smart be elected to the membership of Honorary Fellow of the MSA for his outstanding contribution to both the field of Metrology and the Metrology Society of Australia.
4. That Marianne Philips be elected to the position of auditor for the MSA.

**ANNUAL GENERAL MEETING OF THE
VICTORIAN BRANCH OF THE MSA**

This will be held on the same evening as the AGM for the National body of the MSA at 6:00 pm at NML Clayton.

Nominations for the role of state coordinator and support committee members will be sought for the Victorian Branch.

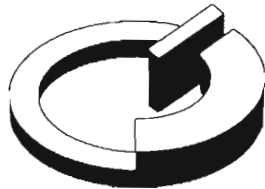

METROLOGY SOCIETY OF AUSTRALIA

APPOINTMENT OF PROXY

To the Secretary
Metrology Society of Australia

_____, Member No _____

Hereby appoint

being a member of the Metrology Society of Australia, as my proxy to vote for me on my behalf at the 2003 AGM of the Society and at any adjournment of that meeting.

Signed:

_____ Date: _____

Note: This Proxy form must reach the Secretary 24 hours before the AGM.

The IMEKO journal "Measurement" is published four times yearly. The following abstract is from an article in a recent edition of the journal, and is reprinted here for the interest of MSA members. If you would like to see what other articles are published in the journal, see the URL below.

A novel remote measurement and monitoring system for the measurement of critical washing parameters inside a domestic washing machine

* David Ward

Via Fornari 46, 20146 Milan , Italy

Received 3 October 2001; received in revised form 23 January 2003; accepted 11 March 2003

Abstract

A patented measurement system has been developed and tested that allows the remote sensing of critical wash parameters directly inside a domestic washing machine via a wireless data acquisition system. The system continuously measures and monitors local flow velocity within the wash load but can easily be adapted to suit or extrapolate other parameters, e.g. shear stress, temperature, humidity etc. The flow measurements are obtained from a peculiar form of the well-tested Pitot tube-probe combined with a piezoresistive type pressure transducer and a matched pair of battery operated 433 MHz hybrid transmitters and receivers. The probe, which is located on the surface of a hollow sphere, captures local dynamic pressure, which can be related to the surface flow velocity. The transducer and transmitter are housed within the sphere that was designed to follow the wash load during the washing cycle and using rapid prototyping technology for its realisation. The receiver, that is mounted outside the machine, picks up the modulated radio signal after which it is processed and stored using a dedicated data acquisition system. This D.A. system is based on a sample-and-hold board, a PCMCIA card and program developed using LABVIEW software. The use of the same probe installed on the inside surface of the washing machine door face and relative experimental results are also discussed.

Reference: *Measurement* 2003 34(3): 187–261.

Keywords : Shear stress; Probe; Wireless measurement; Flow velocity; Washing machine; Soil; Remote

If you would like to read more about this work, see: <http://www.elsevierengineering.com/flat/articles/mech/me260903>

If you would like to see the contents and other abstracts of the IMEKO journal *Measurement*, see: <http://www.sciencedirect.com/science/journal/02632241>



This photograph appeared in TAM 29 on page 8 at a reduced scale. It is reproduced again here somewhat larger for those who wanted to see more detail.

From the NSC - Legal Metrology and Chemistry

It is the responsibility of the National Standards Commission to ensure that industry, commerce, government authorities, the community and our international trading partners have complete confidence in measurements made for trade or regulatory purposes in Australia. For physical measurement there are well-established international legal metrology standards and procedures, whereas the concept of legal metrology in chemistry is relatively new.

In May 2001 the National Standards Commission hosted a workshop on "Chemical Measurements and the Law". A focus of this workshop was to explore possible consequences of legislative changes which would enable chemical measurements of "concentration" to be covered under the provisions of the National Measurement Act. Following this meeting it was agreed that no changes would be made to the National Measurement Regulations in the short term. Instead, the National Standards Commission, in collaboration with the National Analytical Reference Laboratory (NARL), would concentrate on building closer links with stakeholders to identify areas of chemical metrology where a sound evidentiary basis of measurement may be required, and provide appropriate assistance. Such assistance may include the development of systems and infrastructure to support traceability of chemical measurements and/or the drafting of a new legislative framework.

To assist in the development of a legal chemical metrology policy, Dr Brett Yeomans has been seconded to the National Standards Commission from the Australian Government Analytical Laboratories. The goal is to examine the best way to combine the requirements of analytical quality and legal metrology by:

- * reviewing the current situation for legal metrology and chemical measurements in Australia;
- * reviewing and monitoring developments and legislation in other parts of the world, to ensure that future developments in Australia are compatible with international trends; and
- * engaging in discussions with stakeholders in legal chemical measurements in Australia, to identify the relevant needs of the Australian community, and the steps that might be taken to address them.

Chemical measurements differ from many physical measurements in that confirmation of identity of a substance is usually required, as well as (in some cases) measuring the quantity of that substance. Traceability requirements for chemical measurements, and how to achieve traceability of measurement results to national or international standards, are not always clear. Complications can include situations where the measurand is defined by the analytical method being used, and that chemical species are often present in complex matrices, where the nature of the matrix can affect the measured amount of a species. In addition, many chemical analyses are qualitative, where a positive result depends on the detection of a substance regardless of the amount present.

For chemical measurements used for legal purposes, traceability to Australian legal units of measurement can be demonstrated through the use of certified reference materials (as defined by the *National Measurement Act 1960*) or certified measuring instruments. Currently neither mechanism is widespread in the chemical measurement community. For certified measuring instruments, there are a number of International Organisation of Legal Metrology (OIML) recommendations instruments related to chemical measurement, but to date few have been adopted as Australian Standards. Similarly, there are few reference materials that have been certified under the *National Measurement Regulations 1999*.

Given the large number of chemical species that may be subject to analysis, an important issue is the limited availability of pure substance reference materials and matrix reference materials with property values traceable to national standards. Hence, it is important to identify and prioritise the areas of chemical analysis where such traceability is required. NSC's approach is to review regulations and other drivers for undertaking chemical measurement for different sectors (eg environmental measurements, forensic analysis, health and medical testing etc), aiming to identify specific needs in these sectors. In conjunction with police services and NARL, an early priority has been facilitating the certification, under Regulation 48 of the *National Measurement Regulations 1999*, of an aqueous ethanol reference material using a primary method (isotope dilution mass spectrometry) developed by NARL.

The Commission is seeking input on the traceability requirements for chemical measurements used for legal purposes and possible measures to address these requirements, including any specific certified reference material and certified measuring instrument needs. For further information please contact Dr Brett Yeomans on (02) 6213 6146, (02) 9856 0300 or at byeomans@nsc.gov.au. ■

Quantification

If you were in primary school half a century ago the back cover of your exercise books would have had tables giving the relationships between various imperial measurement units. You would have been told that there were 2240 pounds in a ton, and 1760 yards in a mile, and 8 pints to the gallon, and so on. Even today, a student from this era could probably rattle off all these numbers without thinking (try it out on your parents). But that page told about only a small fraction of the units that were in use. Measurements evolved to suit needs, and different trades and industries each came up with their own units, so there were myriad quaint names and relationships. In this column we are going to discuss some of these historical systems. We will also tell you about some of the old units by posing some questions about them, and then give the answers in the following issue. By the time we have finished you will well understand why the SI system was needed.

We will start with some units which have names that have another meaning in the English language. So what do you know about the following units?

| | |
|-------|-------|
| Bar | Chain |
| Cord | Gill |
| Nit | Peck |
| Perch | Pole |
| Rod | Slug |

Finally, a tricky question. The Imperial system is also known as the FPS system, for "foot, pound, second". What quantity does the "pound" represent?

- Jeffrey Tapping

MSA Notes

MSA 2004 Conference Update

The deadline for submitting papers to the MSA 2004 Conference is fast approaching (1st December). The final "Call for Papers" brochure is on the MSA website as a .pdf file and can be downloaded.

The template for the submission of papers is also on the website, only papers submitted using this template will be accepted.

The Conference will begin with a Reception Cocktail party on the Sunday evening when Registration can take place as well. There will be two plenary sessions to begin each day as well as paper presentations, poster displays, trade displays and meetings of Special Interest Groups in the late afternoon. The Conference banquet will be at Sails on the Bay in nearby Elwood.

The foundations are set for a great Conference, all it needs is your participation.

- Steve Jenkins (for the Conference Committee)

Post Nominal Letters for use by MSA Members

Following requests from members, the National Committee discussed the suggested post nominal letters by members of the Society of various grades. The following letters are suggested:

Associate Members: **AMSA**

Full Members: **MMSA**

Fellows: **FMSA**

The use of the above post nominal letters is encouraged in business cards and other appropriate cases.

- Dr Ilya Budovsky, *MMSA*
Honorary Secretary

Requirements for Precision Dimensional Measurement

Richard Duncan,

Duncan Tool & Gauge Pty Ltd
Melrose Park, South Australia
duncantool@bigpond.com

This paper was initially written to give users of a coordinate measuring machine (CMM) an understanding of the factors affecting the machine accuracy during use; it also applies to other methods of measurement. Probably the least understood problem is heat transfer to the CMM and workpiece by radiation.

These are the main factors affecting dimensional measurement to be discussed:

1. Correct temperature measurement and conditions
2. Temperature control of the environment
3. Part temperature stabilisation - soaking
4. Correct measurement strategy
5. Vibration
6. Operator comfort
7. Good drawings and their interpretation

1. Correct temperature measurement and conditions

The measurement of temperature for precision dimensional measurement is not just a matter of putting a thermometer or other temperature measurement device near the object you are measuring and recording the temperature.

An understanding is required of the heat transfer process taking place between the environment, the object being measured and the measuring device.

The process of heat transfer takes place by three modes, conduction, convection and radiation. Radiation is often forgotten. Measurement of the air temperature near the measuring process is unlikely to give you the temperature of the measuring system parts affecting the measurement result.

There could be radiant energy falling on both the measuring equipment and the object being measured. This will add heat to them. The internal parts of the measuring equipment could be producing heat that is being transferred by conduction to the equipment.

Heat transfer is not a one-way phenomenon. Heat will be given out by the equipment and object not only to each other but also to the surroundings. The degree to which this occurs by radiation is dependent on the emissivity of each of them. You

may remember from school physics that a black pot takes a shorter time to heat up than a shiny one. The reverse is the case as the pots cool down, the black one cooling quicker than the shiny one. The measure of this property is called emissivity. It is defined as the ratio of the emissive power of the body to the emissive power of an ideal black body at the same temperature and is given the symbol ϵ .

Here are some values of emissivity for common materials at the same temperature:

| Material | ϵ |
|------------------------------|-------------|
| Aluminium commercial sheet | 0.09 |
| Stainless steel 301 sheet | 0.54 - 0.63 |
| Steel, dark gray surface | 0.31 |
| Cast iron, newly turned | 0.44 |
| Mild steel | 0.2 - 0.02 |
| Brick red, rough | 0.93 |
| Glass | 0.94 |
| Concrete tiles | 0.63 |
| Black or white paint lacquer | 0.80 - 0.95 |

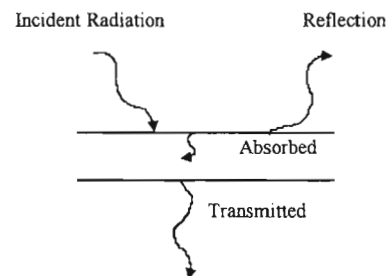

Sketch showing effects of incident radiation.

It is important to realize heat transfer is not a one-way process. As a body is gaining heat from outside sources it is also losing it to the environment. The floor on the whole is likely to be colder than the rest of a room. This can be a source of heat loss not always considered. A surface plate or the table of a CMM can be adversely affected by the heat losses to the floor resulting in unwanted deformation. A simple radiation shield like a shelf added to a surface plate stand or matting or some other non-conducting material under a CMM table will greatly reduce this heat transfer.

Another example of the role that radiant energy plays is when temperature measurement is made without a radiation shield on the thermometer.

Very large errors in temperature measurement can occur if there is a radiation component and it is not removed with a radiation shield. The example below from "Heat Transfer" by J P Holman shows a large temperature measurement error due to the radiation effect from the building walls.

"Example 8-24

A mercury-in-glass thermometer having $\epsilon = 0.9$ hangs in a metal building and indicates a temperature of 20°C . The walls of the building are poorly insulated and have a temperature of 5°C . The value of h for the thermometer may be taken as $8.3 \text{ W/m}^2\text{C}$. Calculate the true air temperature.

Solution

We employ the following equation for the solution (8-124):

$$(T_\infty - T_i) = \epsilon(T_i^4 - T_s^4) \quad T \text{ in absolute units.}$$

Inserting the numerical values, with $T_i = 20^\circ\text{C} = 293 \text{ K}$, $T_s = 5^\circ\text{C} = 278 \text{ K}$, gives

$$(8.3)(T_\infty - 293) = (5.669 \times 10^{-8})(0.9)(293^4 - 278^4)$$

and $T_\infty = 301.6 \text{ K} = 28.6^\circ\text{C}$

In this simple example the thermometer is in error by 8.6°C !"

The steps taken to counteract radiation energy effects are quite often very simple. I have seen cardboard boxes used at a national standards laboratory in to protect equipment from radiation; aluminium foil is also suitable. The provision of a heat shield around a coordinate measuring machine or other measuring equipment need only be a simple structure, consisting of a wood framed resonite partition with windows. The bulb of a mercury-in-glass thermometer can be protected with a piece of aluminium foil. While our body cannot feel low energy heat radiation, we can readily feel the higher energy heat from the sun. The heat energy emitted from a machine tool is usually not felt by us, but it is a source of heat energy in the overall temperature balance of the part and measuring equipment being used. A CMM placed near a cold wall and having on the opposite side a machine tool with a 20 kilowatt rating is like having it near a wall of ice on one side and a number of electric bar heaters on the other. The effect on the CMM will vary as its bridge structure moves further away and nearer to the heating and cooling sources. The air temperature measured in the immediate space around a CMM may well be within acceptable limits but the effect on the actual temperature of the machine

and the part being measured may be very different.

2. Temperature control of the environment.

High precision measurements do need stable temperature conditions. The actual temperature of measurement is less important than stability, rate of change per hour. Poor temperature control is usually worse than no temperature control. Short interval cycling severely degrades a measurement process. If the measurement temperature is known and stable then calculations can be done to convert the size of different materials to the standard temperature of 20°C .

A standard room air conditioner is not suitable without modification. Smooth control of the heat input and removal is important. A proportional controller although expensive is better than on-off control. A rate of temperature change of $0.5^\circ\text{C}/\text{hour}$ is often quoted as suitable but for low uncertainty measurements this may need to be halved. A constant change in temperature of $0.5^\circ\text{C}/\text{hour}$ is not acceptable, i.e. 4°C in 8 hours. The lag in the temperature of large measuring equipment to that of a small object being measured can cause significant errors.

3. Part temperature stabilisation - soaking

It is important to allow parts to come to the measurement temperature and to realize that as the part temperature approaches the surrounding temperature so the rate of change decreases.

$$q = -kA \frac{dT}{dx} \quad \text{where } q \text{ is the heat transfer rate and } \frac{dT}{dx} \text{ is the temperature gradient}$$

For usual engineering dimensional measurements of small objects of up to approximately 300 mm in size where the uncertainty of measurement is of the order of $\pm 10 \text{ mm}$, a few hours should be sufficient. When very high accuracy measurements like the calibration of gauge blocks is being done more time is needed. Putting the part to be measured on a metal surface in the measurement environment can decrease the soak time. It should be remembered granite has a far lower specific heat than metals and is not as effective. A large mass such as a CMM table can take months to come to within 0.5°C of its new environment temperature even when its initial temperature only differed by a few degrees.

Different materials and metals change length at different rates. A useful value to remember is that steel changes in length by about 12 mm per metre per 1°C , aluminium by 24 mm and brass



continued on page 22

MSA Members

Overseas

Mr Noel G Cayron, Singapore
Dr Lawrence A Christian, NZ
Mr Geoffrey D Clark, NZ
Mr Tjhang Hendri, Singapore
Mr Lyndon P Kapoor, NZ
Dr Alexander S Katkov, Russia
Mr Arsemar L Poblete,
Philippines
Mr David Soucy, Canada

ACT

Mr Barry A Stokker
Dr Brett D Yeomans

NSW

Mr David G Adkins
Mr Jeffrey R Andrews
Mr Mile Arnautovich
Mr Errol G Atkinson
Mr Vasukan Balakrishnan
Mr Trevor J Bell
Dr Judith M Bennett
Mr Ian Bentley
Dr Laurie M Besley
Dr Noel Bignell
Dr Stephen Boronkay
Mr Lyndon S Branscomb
Mr Graham R Brown
Mr Stan Brulinski
Dr Ilya Budovsky
Mr Douglas M Burgess
Mr Bruce J Cameron
Mr Adrian J Caster
Mr Khaled Chahine
Mr Jung Chen
Dr Henry Chen
Mr Neil G Ciclovan
Mr Philip E Ciddor
Dr Anthony F Collings
Mr John J Connolly
Mr Peter C Coogan
Mr Michael J Cook
Mr Maxwell M Cuthbertson
Ms Judith Cuthbertson
Dr Stephen J Dain
Dr Michael P J Daly
Mr Florian de Celis
Mr Gerard J de Groot
Mr Barry J Deeth

Mr William Deusien
Mr Laurence P Dickinson
Mr Gary L Dykes
Mr John R Ebsary
Mr Frederick S Emms
Ms Kitty M O Fen
Mr Kerry D Fernandez
Mr Stuart W Findley
Mr Terrance Flynn
Mr Robert B Frenkel
Dr James L Gardner
Mr Robert Geyer
Mr Michael A Gibbs
Dr David R R Gowdie
Mr Donald G Groeneveld
Mrs Marian T Haire
Mr Bruce F Hardiman
Dr Grahame Harvey
Mr Philip S Heskett
Prof Bryn Hibbert
Dr John D Hunter
Dr Barry D Inglis
Mr Anthony J Jackson
Ms Xihu Jiang
Dr Leigh Johnson
Mr Mario R Jueco
Mr Robert G Kelly
Mr Franz Kocijan
Mr Umesh B Kotwal
Mr Doan D Lam
Mr Peter L Langley
Mr Victor Lawrence
Dr Yi Li
Mrs Hongwei Lu
Mr Lee Macer-Wright
Mr Noel J MacGregor
Dr Lindsey G Mackay
Dr John K L Man
Mr Antal Mark
Mr Peter A Mayo
Mr Patrick G McErlain
Mr Bruce H Meldrum
Mr Jim Miles
Mr Ian J Monro
Dr Edwin C Morris
Dr Bruce R Morrison
Mr Ben Mosman
Mr Richard Myors
Mrs Kim M Nguyen
Mr Gregory E O'Donnell

Ms Helen M Palfreeman
Mr John E Peters
Mr Ronald W Petto
Mr Paul E Pokorny
Mr Ian D Pope
Mr Gary W Price
Mr Brian J Pritchard
Ms Hong Qin
Dr Brian W Ricketts
Mr Robert G Rigby
Ms Regina L Robertson
Dr Juris Rungis
Ms Mary A Ryan
Ms Glenda A Sandars
Mr Greig W Small
Mr Alan Squirrel
Mr Kip Stavrou
Mr Malcolm C Stephen
Ms Maree-Ann C Stuart
Ms Dunia Sukkar
Mr Barry J Sutcliffe
Mr Eric G Thwaite
Mr Cesar Torres
Dr Kostas Tsampazis
Dr Martin J Turner
Mr Peter R Underwood
Mr John R Walsh
Dr Christopher J Walsh
Mr Julian F Wilson
Mr Robert C Woo
Mr William H Wright
Ms Ruimin Yin
Ms Jana J Zeleny

NT

Mr Leslie G Anderson
Mr Francis J Osborne

QLD

Mr Terrence W Albury
Mr Geoffrey C Barnier
Mr Shane W Brann
Mr John P Browne
Mr John J Darling
Mr Peter E Gardener
Mr John P Gilluley
Mr Glen A Hay
Mr Kim Irving
Mr David G Johnston
Mr Ian T Kendall

Mr Karl Kozehuba
Mr Nigel S Lane
Mr John R Leinster
Mr Donald A MacQueen
Mr David V Martin
Mr Barry Neville
Mr Robert G Otto
Mr Damian F Ousley
Mr Brian Phillips
Mr Raimondo A Pippia
Mr Maxwell E Purs
Mr Attila L Szvetko

SA

Prof Andrew H Baghurst
Mr Hendrik J Blackie
Mr Glyn W Byrne
Mr Dennis G Cooper
Mr Harry G Downs
Mr Richard A Duncan
Mr Leslie C Felix
Mr David A Gray
Mr Mark C Histed
Mr Maurice J Hooper
Mr Walter Iwanicki
Mr Richard Laslett
Mr Dennis W Leaney
Mr Emanuel J Mallia
Mr Ian D Maxted
Mr Mark P McEwen
Mr Ian Miller
Mr James Moros
Mr Marco Rossi
Mr Harold R Stasinowsky
Mr Jeffrey Tapping
Mr Graham L Taylor
Mr Heinz G Vogt
Mr Ross Wiley
Mr Matthew S Wojcik
Mr Uwe Zahradnik

TAS

Mr Murray C Gordon
Mr Kevin J O'Brien
Mr Ronald S Plummer
Mr Jonathan J Rehrmann

VIC

Mr Anthony B J Adaman
Mr Joseph P P Alesi
Mr Randall A Anderson
Mr Dale W Atkinson
Mr Geoffrey Baker
Mr Kenneth J Bassett
Mr Maxwell J Baxter

Mr Peter J Beggs
Mr Michael J Bindon
Mr William J Blackson
Mr Gary R Brechin
Mr Ronald P Breen
Mr Robert J Britton
Mr Ricky W Byers
Mr Peter J Carmody
Mr Alan B Catt
Mr Ronald R Cook
Mr Jack C Deller
Mr Brendon Dickins
Mr John G Doering
Mr Jack V Duce
Mr Mark N Duce
Mr Ulrich Duenzl
Mr John C Dundas
Mr Anthony S Dyke
Mr Wayne V Eames
Dr Brian J Egan
Mr Patrick S Fogwill
Dr Bruce W Forgan
Mr Ronald Fronda
Mr Walter J Giardini
Mr James Gordon
Mr Bruce S Grigson
Mr Michael L Hadley
Mr Greg P Hayes
Mr Robert N Hessing
Mr Robin Hiscock
SQNLDR Peter R Hodgson
Mr Steven J Huggard
Mr Andrew J Jackson
Dr Stephen E Jenkins
Mr William A Johnstone
Mr Tim J Kennon
Mr Leonard W Kerwood
Mr Bojan Kocet
Ms Maureen Koegel
Mr Emil Kosmina
Mr Dennis M Lam
Mr Bernard Lebenbaum
Dr Helen Liddy
Mr David L Little
Mr Graham F Lucas
Mr Leigh J Mackinnon
Mr Angel G Maluyo
Mr Ian D Martin
Mr Ronald L McBain
Mr Stuart R McDonald
Dr John R Miles
Mr John C Mitchell
Mr Julio O Mondragon
Mr Russell S Monger
Mr John R Newman

Mr Kevin M O'Donnell
Mr Ian C Ogilvie
Mr Bonifacio M Olaver
Mr Neville J Owen
Mr Mario Padalini
Mr Mark R Poynder
Mr Ian W Prosser
Mr Rodney W Pyke
Mr John W Ralton
Mr David Roberts
Mr Philip C Sanders
Mr Graeme A Savige
Mr Gerhard A Schaller
Mr David A Schneider
Mr Denis G Sexton
Mr Horst W Sieker
Mrs Carol A Sieker
Mr Benedykt Simankowicz
Ms Galina Sirant
Mr Alex Smart
Mr Timothy Smyth
Mr Michael J Snell
Mr Andrew Spurling
Mr Paul Standaert
Mr John A E Sumner
Mr Stephen Theuma
Mr Mark D Thomas
Mr Alfred Tiedemann
Mr Kenneth E Ward
Dr Jane O Warne
Mr Steve C White
Mr John D Widdowson
Mr John V Wild
Mr Alan E Worroll
Dr Howard P Wright
Mr Paul J Zechovsky

WA

Mr Derek Ball
Mr Hilary Bulner
Mr Graham R Cox
Mr Robert W Crawford
Mr Philip R Dickson
Mr Peter A Dobson
Mr Peter R Duncan
Mr Kevin P A Durney
Mr Louis G Hoekzema
Mr Werner Nickel
Mr David J Pack
Mr Douglas W Simpson
Mr Terry Wayman

by 18 mm.

4. Correct measurement strategy

It is often not understood that the surfaces of the workpiece being measured are not perfect. Too few measurement points for instance on a round hole may give a wrong result. Figure 18.47 from "Handbook of Geometrical Tolerancing" by G Henzold shows dramatically the differences that you could assign to the centre of a hole by different measurement strategies.

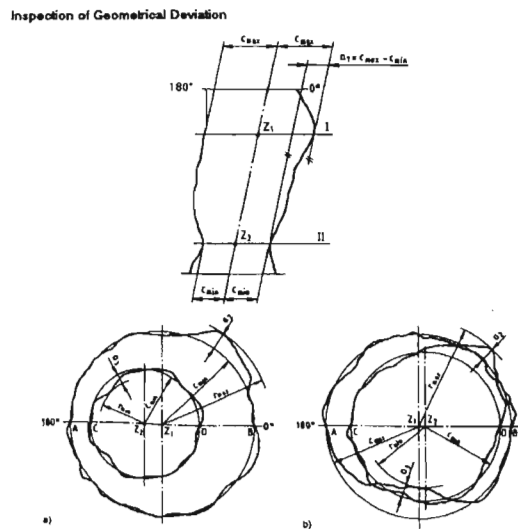

Figure 18.47: Extreme positions method, evaluation: (a) when the radial profiles do not intersect; (b) when they do.

While three points on the circumference of a perfect circle define it precisely, the circles found in practice are rarely perfect. Similarly a flat surface is not truly flat. If a flat datum surface is placed on a good surface plate it will take up a particular position and may or may not rock. When an operator probes a flat surface with a CMM it is highly likely that the points he has chosen will give a different alignment to that given when it is placed on a surface table. It was often said that the old surface plate method and new CMM methods of measurement give different results. The real problem is that the methods used for alignment are significantly different. To properly align a datum using a CMM needs a similar strategy to that of placing it on a flat datum surface. Datum alignment and measurement using a CMM needs many more points to be taken than generally considered necessary.

5. Vibration

Vibration can also be a problem. The placing of accurate measuring equipment near press lines and other vibration producing equipment should be

avoided. The cost of fitting anti vibration footings to measuring equipment will be very expensive and it is not always entirely satisfactory. The siting of a dimensional metrology laboratory near a busy road should be avoided if there is a more suitable site.

6. Operator Comfort

Operator comfort should be considered when designing measurement facilities or placing measuring equipment. Good lighting is important as is a relatively noise free environment. Windows should be provided so that the operator does not feel cut off from the outside world. It is also important that other people can see what is happening and measurement is not done in "secret". The provision of suitable working bench space and seating is also important.

7. Good drawings and their correct interpretation

Good drawings that simply and unambiguously describe the designer's requirements are very important. Only completely toleranced drawings enable the production of workpieces that are as precise as necessary and as economic as possible. In the last twenty years international drawing standards and the standards for geometric tolerancing have been greatly enhanced and it is now possible to specify what is needed when they are used properly. For the system to work properly both the designer-draughts person and user must have had a thorough training and properly understand drawing requirements and geometric tolerancing.

Bibliography

Henzold, G (1995). Handbook of Geometrical Tolerancing, John Wiley & Sons Ltd, West Suss England

Holman, J P (1989). Heat Transfer, McGraw-Hill Book Co - Singapore

Book Review

The Measure of Reality, Quantification and Western Society 1250-1600

Alfred W. Crosby, Cambridge University Press, ISBN 0-521-55427-6

This book will appeal to those who like to view a layer or two of meaning below the story. Yes, the title says it is about the history of measurement, but it is really about the rise of science and technology in Europe, and the part played by many factors, including measurement, mathematics, art and double-entry book-keeping in this process. Along the way it discusses religious and social philosophy, and the influences that these had on people's attitudes. There were some elements of this in *The Measure of All Things*, reviewed by Jane Warne in the March issue, for example the relationship between the desire for an objective basis for measurement units and the desire for liberty, equality and fraternity by the French revolutionists. But while *The Measure* addressed a narrow slice of history and topic, this book looks at a much broader canvas. The title says that the study begins in the thirteenth century, but it actually begins with the Greek philosophers Plato and Aristotle, because the world-view taught by them dominated European thinking until well past the first millennium. These Greeks considered mathematics to have a mystical nature, while measurement was a low-class activity not to be considered by intellectuals, so they did not look at connections between the two. Crosby suggests that Greek surveyors probably knew about Pythagoras's theorem long before Pythagoras expounded it.

Crosby is an historian, and it shows in the ordered structure of the chapters. Titles include Time (which discusses clocks and calendars), Space (maps and astronomy), Mathematics (number systems, decimal notation, numerology), Visualisation (scripts and writing), Music (scales and timing), Painting (perspective and reality), and Bookkeeping (precise quantification of goods and money, and the influence of this on enterprise). In each chapter Crosby traces practices through the period of the title, and looks at the evolution of the subject and its influence on European society.

I found the prose a little less than smooth, but if I

could gloss over these minor failings the story was absorbing. I loved the little morsels of interesting history describing how some things were seen quite differently in the past. For example a thousand years ago it was not obvious that measurements were universal, so they did not necessarily assume that a quantity had the same value on the equator as it did at the pole. And is this such a strange thing, when there is speculation today whether the gravitational constant has been the same through the history of the universe. These are parables teaching us to try to have an open mind, and not be constrained by current dogma.

In his introduction Crosby says that this is his third book in the quest to find the reasons for the relative dominance of European technology, and I found it a bit puzzling that he did not sum up at the end and draw any explicit conclusions. To me, his evidence points towards not just one factor, but also ranges of factors with each driving the others in a positive feedback loop. I invite you to read the book and make your own judgement.

- Reviewed by Jeffrey Tapping

SOLUTION TO THE TAM CROSSWORD

Believe it or not, no-one was able to complete the Metrology crossword in issue 29 of TAM completely correctly, and go on to win the excellent book prize "The Measure of All Things" by Ken Alder. The competition is therefore closed, and the solution is given below.

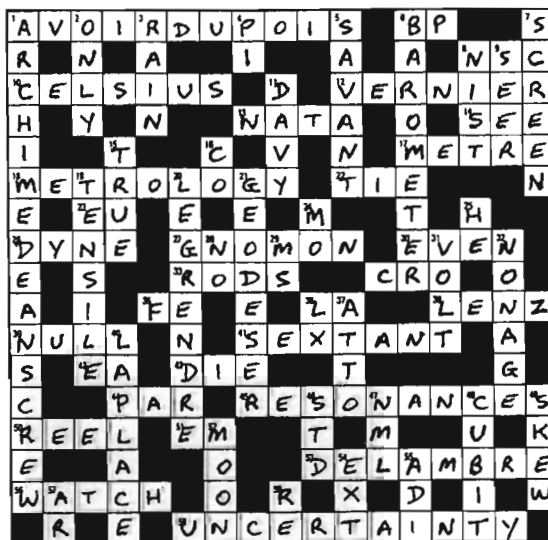

MSA Management Committee

President
Dr Jane Warne
(03) 9669 4721
Bureau of Meteorology

Vice-president
Mr Walter Giardini
(03) 9545 2069
CSIRO (NML)

Secretary
Dr Ilya Budovsky
(02) 9413 7201
CSIRO (NML)

Treasurer
Ms Marian Haire
(02) 9856 0353
NSC

Members
Dr Jim Gardner
(02) 9413 7323
Mr Tony Jackson
(02) 4724 4984
WorkCover
Dr Stephen Jenkins
0421 351 002
Mr Jim Miles
(02) 9760 6575
TAFE Commission
Mr Neville Owen
(03) 9556 6219
Gas Technology Services
Mr Brian Phillips
(07) 3372 0430
Weigh-Tech Cid Pty Ltd
Mr Dennis Sexton
Mr John Widdowson
(03) 9329 1633
NATA

National Liaison Officer
Mr Tony Jackson
(02) 4724 4984

Marketing
Mr Horst Sieker
(03) 9295 8700

State Contacts
NSW Mr Brian Pritchard
(02) 9413 7322 (wk)
CSIRO NML
Fax (wk) (02) 9413 7202
e-mail Brian.Pritchard@csiro.au
QLD Mr Rai Pippia
(07) 3407 5410 (wk)
Energex Ltd
e-mail aipippia@energex.com.au
SA Mr Leslie Felix
(08) 8354 1355 (wk)
Abstec Calibrations
e-mail abstec@abstec-calibrations.com.au
TAS Mr Jonathan Rehmann
(03) 6324 4613 (wk)
ACL Bearing Company
Fax (03) 6326 6600
e-mail Jonathan.Rehmann@bc/a.cl@acl.com.au
VIC Mr Mark Thomas
(03) 9244 4042 (wk)
Fax (wk) (03) 9244 4004
e-mail mthomas@netspace.net.au
WA Mr David Pack
(08) 9291 9147 (wk)
Gas Measurement & Auditing Pty Ltd
Fax (wk) (08) 9291 9147
e-mail gasmeasurement@bigpond.com

WHAT'S ON

MERA TRADE FAIR

10th International Trade Fair for
Measurement Control and Automation
Technology Moscow, Russia
3-6 November, 2003
www.msi-fairs.com/merover.htm

MSA 2004 - Valuing Metrology

The Metrology Society of Australia's
5th Bi-Ennial Conference
Melbourne
March 2004

IMEKO - Photonics in Measurement

Technical Committee TC2
16th Symposium on Photonics in
Measurement
Frankfurt am Main, GERMANY
23-24 June, 2004
www.imeko.org

MSA 2004 - Valuing Metrology

The Metrology Society of Australia's
5th Bi-Ennial Conference in
Melbourne March 2004.

The Metrology Society of Australia will be holding its 5th Bi-Ennial Conference in Melbourne during the month of March 2004. The main theme of the conference is Valuing Metrology. A significant fraction of the countries gross national product "disappears" in measurement, but what do we get for it? What does measurement add to the value of a business? How does metrology improve the quality of the products? Government, businesses and industry sectors are all asking these hard questions.

Tell your colleagues about the conference and pencil it into you diary. See you in Melbourne in March 2004, great weather, great events and great fun.



Next Issue

- From the AGM
- Conference Information

Call for Papers

We are looking for technical papers on new methods or measurements and standards. What are the new and clever ways in which the science of metrology is being advanced? How is metrology being applied at the shop floor level? But we are also looking to open up discussion on the broader issues facing metrologist. How do you demonstrate the contribution your metrologists add to the business in a tangible way?

Start drafting your papers now, (September closing date).

THE AUSTRALIAN
METROLOGIST

A publication of the Metrology Society of Australia

Telephone: (08) 8365 2451

E-mail: maurieh@ozemail.com.au

Website: www.metrology.asn.au